

# Input: 120V 50/60Hz Output: 12V 1.5A BATTERY CHARGER

## IMPORTANT SAFETY INSTRUCTIONS: SAVE THESE INSTRUCTIONS

THIS MANUAL CONTAINS IMPORTANT SAFETY AND OPERATING INSTRUCTIONS FOR

Model No. 9002A

KEEP IT WITH OR NEAR CHARGER AT ALL TIMES.

1. **WARNING: RISK OF EXPLOSIVE GASES WORKING IN VICINITY OF A LEAD-ACID BATTERY IS DANGEROUS. EXPLOSIVE GASES DEVELOP DURING NORMAL BATTERY OPERATION. IT IS IMPORTANT THAT EACH TIME BEFORE USING YOUR CHARGER, YOU READ THIS MANUAL AND FOLLOW THE INSTRUCTIONS EXACTLY.**
  - 1.1 To reduce risk of battery explosion, follow these instructions and those published by battery manufacturer and manufacturer of any equipment you intend to use in vicinity of battery. Review cautionary marking on these products and on engine.
  - 1.2 Do not expose charger to rain, snow, or liquids.
  - 1.3 Use of an attachment not recommended or sold by the battery charger manufacturer may result in a risk of fire, electric shock, or injury to persons.
  - 1.4 To reduce risk of electric shock, unplug charger from AC outlet before attempting any maintenance or cleaning.
  - 1.5 To reduce risk of damage to electric plug and cord, pull by plug rather than cord when disconnecting charger.
  - 1.6 An extension cord should not be used unless absolutely necessary. Use of improper extension cord could result in a risk of fire and electric shock. If extension cord must be used, make sure that pins on plug of extension cord are the same number, size and shape as those of plug on charger and that the extension cord is properly wired and in good electrical condition and that the wire size is large enough for A.C. ampere rating of charger as specified in the following table:

RECOMMENDED MINIMUM AWG SIZE FOR EXTENSION CORDS FOR BATTERY CHARGERS				
Length of cord (feet):	25	50	100	150
AWG size of cord:	16	16	16	14
  - 1.7 If charger is equipped with an input power cord, do not operate charger with damaged cord or plug - replace the cord or plug immediately.
  - 1.8 Do not operate charger if it has received a sharp blow, been dropped, or otherwise damaged in any way; take it to a qualified serviceman.
  - 1.9 Do not disassemble charger; take it to a qualified service center when service or repair is required. Incorrect reassembly may result in a risk of electric shock or fire.
  - 1.10 Appliances incorporating batteries which contain materials hazardous to the environment:
    - 1.10.1 Batteries contain lead and dilute sulfuric acid. Dispose of the battery in accordance with federal, state and local regulations. Do not dispose of the battery in a landfill, lake or other
    - 1.10.2 Scrap and replace the VRLA battery at or before the time indicated on the battery or in the user's manual. Usage beyond the required time of service can cause fluid leakage due to damages to the container, or cause fire due to power leakage.
2. **PERSONAL PRECAUTIONS**
  - 2.1 The appliance is not intended for use by young children or infirm persons without supervision; young children should be supervised to ensure that they do not play with the appliance.
  - 2.2 When the battery charger is charging for automobile batteries, the following steps should be done:
    - 2.2.1 The battery terminal is not connected to the chassis has to be connected first. The other connection is to be made to the chassis, remote from the battery and fuel line. The battery charger is then to be connected to the supply mains.
    - 2.2.2 After charging, disconnect the battery charger from supply mains, and then remove the chassis connection and the battery connection, in this order.
  - 2.3 If the supply cord is damaged, it must be replaced by the manufacturer or its service agent or similarly qualified person in order to avoid a hazard.
  - 2.4 Someone should be within range of your voice or close enough to come to your aid when you work near a lead-acid battery. Have plenty of fresh water and soap nearby in case battery acid contacts skin, clothing or eyes. Wear complete eye and clothing protection. Avoid touching eyes while working near batteries.
  - 2.5 If battery acid contacts skin or clothing, wash immediately with soap and water. If acid enters eye, immediately flush eye with running cold water for at least 10 minutes and get medical attention immediately.
  - 2.6 NEVER smoke or allow a spark or flame in vicinity of battery or engine.
  - 2.7 Be extra cautious to reduce risk of dropping a metal tool onto battery. It might spark or short-circuit battery or other electrical part that may cause explosion.
  - 2.8 When working with a lead-acid battery, remove personal metal items such as rings, bracelets, necklaces, watches, etc. A lead-acid battery can produce a short-circuit current high enough to weld a ring or the like to metal, causing a severe burn.
  - 2.9 Use charger for charging a 12 Volt Lead-Acid Battery. The rated capacity of the battery should be 30AH maximum. The charger can charge LEAD ACID battery only. It is not intended to supply power to a low voltage electrical system other than in a power supply application. Do not use battery charger for recharging dry-cell or non-rechargeable batteries that are commonly used with home appliances. These batteries may burst and cause injury to persons and damage to property. While charging an impropriety type of battery, it will cause battery serious damage.
  - 2.10 NEVER charge a frozen battery.
  - 2.11 NEVER charge the impropriety type of battery.
  - 2.12 NEVER charge the impropriety Voltage of battery.
3. **PREPARING TO CHARGE**
  - 3.1 If necessary to remove battery from vehicle to charge, always remove grounded terminal from battery first. Make sure all accessories in the vehicle are off, so as not to cause an arc. Be sure area around battery is well ventilated while battery is being charged. Gas can be forcefully blown away by using a piece of cardboard or other non-metallic material as a fan.
  - 3.2 Clean battery terminals. Be careful to keep corrosion from

coming into contact with eyes. Add distilled water in each cell until battery acid reaches level specified by battery manufacturer. This helps purge excessive gas from cells. Do not overfill. For a battery without caps, carefully follow manufacturer's recharging instructions.

- 3.3 Study all battery manufacturers' specific precautions such as removing or not removing cell caps while charging and recommended rates of charge.
- 3.4 Determine voltage of battery by contacting battery manufacturer and make sure it matches output rating of battery charger.

#### 4. CHARGER LOCATION

- 4.1 Locate charger as far away from battery as DC cables permit.
- 4.2 Never place charger directly above battery being charged; gases from battery will corrode and damage charger.
- 4.3 Never allow battery acid to drip on charger when reading gravity or filling battery.
- 4.4 Do not operate charger in a closed-in area or restrict ventilation in any way.
- 4.5 Do not set a battery on top of charger.

#### 5. DC CONNECTION PRECAUTIONS

- 5.1 Connect and disconnect DC output terminals only after removing charger from AC outlet.
- 5.2 Never allow DC output terminals to touch each other.
- 5.3 If problems arise connecting the output leads, solicit the aid of your Dealer from whom you purchased this product or the charger manufacturer for finding a suitable connection device for your application.  
Attach clips to battery and chassis as indicated in 6.5 through 6.7 and 7.2 through 7.4.

#### 6. FOLLOW THESE STEPS WHEN BATTERY IS INSTALLED IN VEHICLE. A SPARK NEAR BATTERY MAY CAUSE BATTERY EXPLOSION. TO REDUCE RISK OF A SPARK NEAR BATTERY:

- 6.1 Position AC and DC cords to reduce risk of damage by hood, door or moving engine part.
- 6.2 Stay clear of fan blades, belts, pulleys, and any other parts that can cause injury to persons.
- 6.3 Check polarity of battery posts POSITIVE (POS., P, +) post usually has larger diameter than NEGATIVE (NEG., N, -).
- 6.4 Determine which post of battery is grounded (connected) to chassis. If negative post is grounded (as in most vehicles), see paragraph 6.6.
- 6.5 If positive post is grounded, see paragraph 6.7.
- 6.6 For negative-grounded vehicle, first connect POSITIVE (RED) clip from charger to POSITIVE (POS., P, +) ungrounded post of battery. Then connect NEGATIVE (BLACK) terminal to vehicle chassis or engine block away from battery.
- 6.7 For positive-grounded vehicle, connect NEGATIVE (BLACK) clip from charger to NEGATIVE (NEG., N, -) ungrounded post of battery. Connect POSITIVE (RED) clip to vehicle chassis or engine block away from battery keeping the battery terminal well removed there from.
- 6.8 Do not connect any charger clips to carburetor, fuel lines, or sheet-metal body parts. Connect to a heavy gauge metal part of the frame or engine block.
- 6.9 Connect charger AC supply cord to electrical outlet
- 6.10 When disconnecting charger, turn switches (if supplied) to off, disconnect charger from AC power, remove clip from vehicle

chassis, and then remove clip from battery terminal. See operating instructions for length of charge information.

#### 7. FOLLOW THESE STEPS WHEN BATTERY IS OUTSIDE VEHICLE. A SPARK NEAR THE BATTERY MAY CAUSE BATTERY EXPLOSION. TO REDUCE RISK OF A SPARK NEAR BATTERY:

- 7.1 Check polarity of battery posts. POSITIVE (POS., P, +) battery post usually has a larger diameter than NEGATIVE (NEG., N, -) post. Some batteries are equipped with 'Wing-Nut' terminals allowing for easy placement of the terminals to these posts.
- 7.2 Attach at least a 24-inch long 6-gauge (AWG) insulated battery cable to NEGATIVE (NEG., N, -) battery post.
- 7.3 Connect POSITIVE (RED) charger terminal to POSITIVE (POS., P, +) post of battery.
- 7.4 Position yourself and free end of cable as far away from battery as possible - then connect NEGATIVE (BLACK) terminal to free end of cable.
- 7.5 Do not face battery when making final connection.
- 7.6 Connect charger AC supply cord to electrical outlet
- 7.7 When disconnecting charger, always do so in reverse sequence of connecting procedure and break first connection while as far away from battery as practical
- 7.8 This on board battery charger is also suitable for charging to a marine (boat) battery, it is also designed to charge for marine use.

#### 8. OPERATING INSTRUCTIONS

- 8.1 Once the connection instructions have been followed, plug-in AC power cord, the "POWER" Red (LED) will be on, the charger will begin charging automatically and the "CHARGING" Yellow (LED) will be on during charging. When the battery is fully charged the "CHARGING" Yellow (LED) will be off and the "FULL/FLOAT" Green (LED) will be on. Float Mode allows the charger to effectively be left connected to your batteries, over the course of a season, without overcharging your batteries and maintains your battery's full charge.

#### 9. Specifications

- 9.1 Input voltage: 120Vac 50/60Hz 0.4A Max.
- 9.2 Charging starting conditions: Battery not less than 5.5V
- 9.3 Rating output: 12Vdc 1.5A
- 9.4 Battery type: Lead-acid battery
- 9.5 Maximum charging voltage: 14.4V
- 9.6 Maintenance charging voltage: 13.2V-14.0V
- 9.7 Operating Environmental: -10-40°C, 90% RH Maximum
- 9.8 Weight: 0.62Lbs (0.28kg) approx.
- 9.9 Dimensions: L4.65" x W1.18" x H2.83" (L118 x W30 x H72mm)

## 10. REVERSE BATTERY / OUTPUT PROTECT CONDITION.

The charger has reverse battery and output short circuit protection. If a reverse battery charger condition exists ("FAULT" Red L.E.D.) solid, while output leads are connected backwards), simply unplug charger from AC power and properly remake the connections as described in this manual.

## 11. INSTALLATION

### 11.1 Mounting the charger to vehicle:

The battery charger is mounted directly to the fender well of your vehicle as shown in figure -1. If using the nuts and bolts provided, drill two 1/8" holes in diameter. If the backside of the mounting surface is hard to reach, you may consider using two 1/2" long sheet-metal screws (not supplied) instead of the nuts and bolts provided.

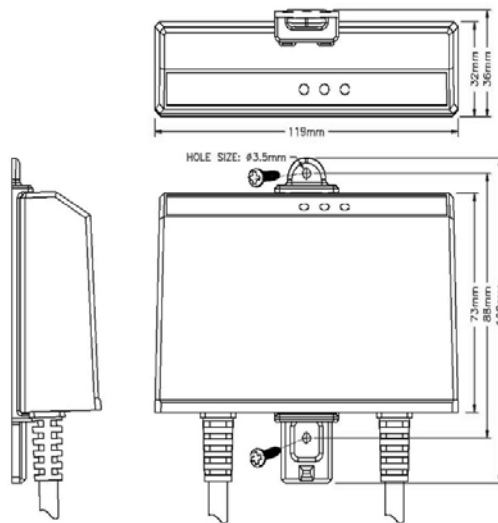

Figure 1

### 11.2 Mounting the charger along side the battery:

If more convenient to do so, as the following figure-2, using the mounting bracket (supplied) to mount the battery charger along side of the battery. If possible, mount the charger to the side of the battery away from the engine and fan blades. Mount the bracket to the charger as shown, using the nuts and bolts provided. Loosen the battery retaining hardware enough that you can insert the bracket between the bottom of the battery and the battery mounting tray as shown. Position the charger so that it will not rub against the battery or any other part of the vehicle, and then tighten the battery retaining hardware.

**CAUTION: Do not drill or puncture the battery.**

**Electrical Installation** – The output leads of the charger are terminated ring lugs. Install the ring lugs on the bolt-head side of the battery terminal (see figure 3). Route and secure the AC cord and the output wiring away from the gas line, carburetor or other hot, sharp or moving and pinch parts to avoid damage to the insulation. Secure the AC cord using a

cable tie or equivalent.

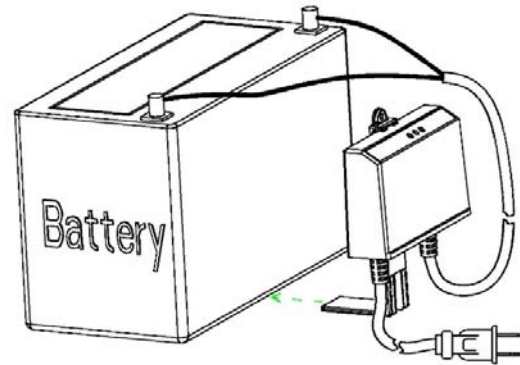

Figure 2

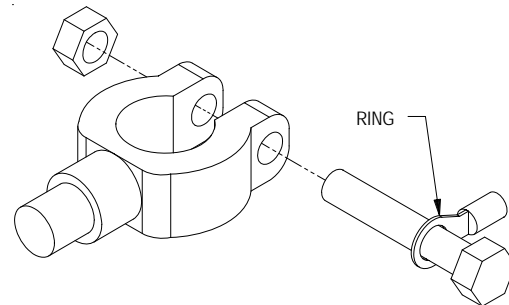

Figure 3

## 12. MAINTENANCE

Store in a clean and dry place; occasionally clean the case and cords with a dry cloth.