

ITEM	PART NO.	DESCRIPTION	DWG. NO.	QTY
21	030-0688	CRTN,PACKING	B4155	1
22	030-0689	CRTN,UNIT	D5149	1
23	SEE CHART 2	MANUAL,	SEE CHART 2	1
24	030-0307	CRTN,MASTER	D4488	.167
25	SEE CHART 2	UPC LABEL UNIT	SEE CHART 2	1
26	SEE CHART 2	UPC-MASTERPACK LABEL	SEE CHART 2	1

REV	REVISION	ECN	BY	APPR	DATE
	SEE SHEET 1 FOR REVISIONS				

CHART 2

MODEL NO.	ITEM	PART NO.	DESCRIPTION	DRAWING	QTY
6024	23	027-0782	MANUAL,6024	W2256	1
	25	151-0242	UPC,6024 UNIT	N/D	1
	26	151-0243	UPC,6024 MSTR-PAK	N/D	1
BT6024	23	027-0790	MANUAL,BT6024	W2277	1
	25	151-0251	UPC,BT6024 UNIT	N/D	1
	26	151-0252	UPC,BT6024 MSTR-PK	N/D	1

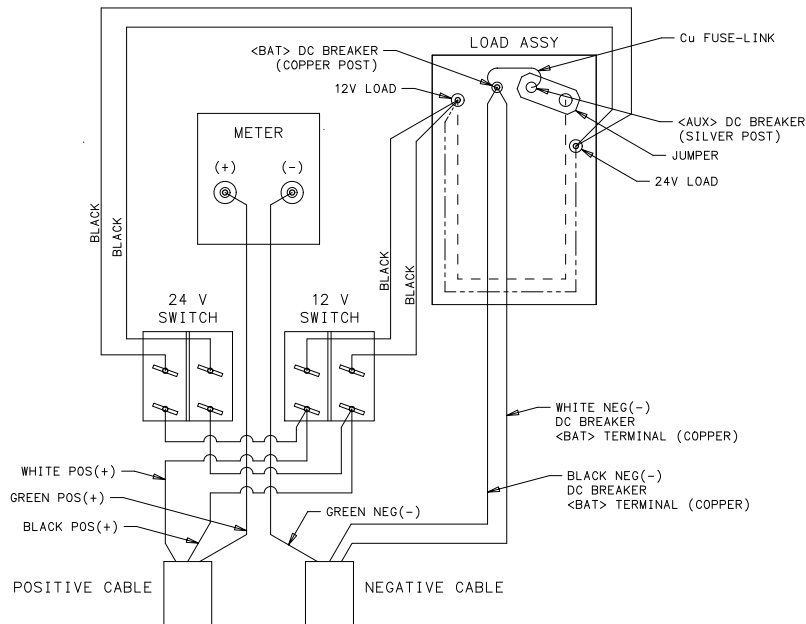
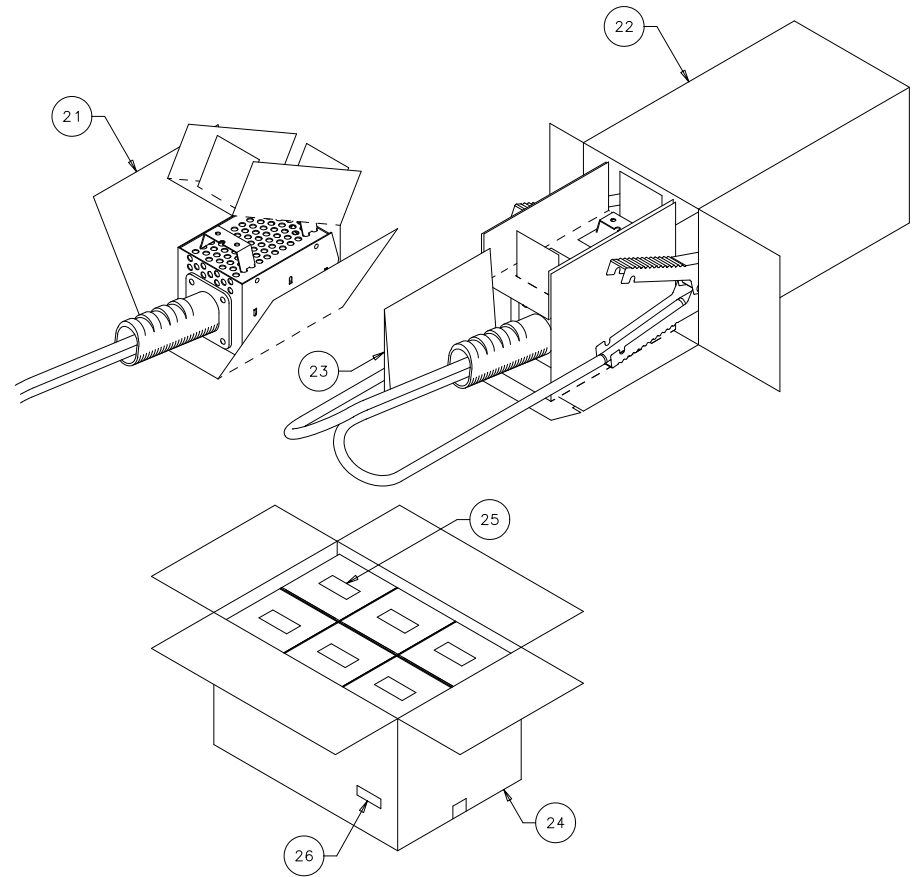

- NOTES:
13. MASTER CARTON (#26) IS TAPED ON BOTTOM & TOP.
  14. UNIT CARTONS (#24) MUST BE INSERTED INTO MASTER CARTON WITH TOP FLAP OF CARTON FACING UP. ALL TEXT SHOULD FACE THE SAME DIRECTION.
  15. ALL MASTER CARTONS WILL CONTAIN 6 UNITS.
  16. MASTER CARTONS WILL BE STAMPED USING BLACK INK ON ANY TWO ADJACENT SIDES, PER CARTON MARKING SPEC 006-0087.

ASSOCIATED EQUIPMENT CORP. ST. LOUIS, MISSOURI 63115					
B4158 DWG NO.	DIMENSIONS ARE IN INCHES UNLESS OTHERWISE SPECIFIED UNLESS OTHERWISE SPECIFIED TOLERANCES ARE		TITLE ASSEMBLY, HAND HELD TESTER (6024 TYPE)		
	FRACTIONAL : 1/64	DECIMAL : .01	DRAWN BY D. FOGARTY	DATE 07/29/04	SCALE NTS
	ANGULAR : 5°	DO NOT SCALE DRAWING	CHECKED BY	DATE	PROJECT NO.
	PART NO. CHARTED		DRAWING NO. B4158		REV.